

Rule 5.2 Parking, Loading and Access

Rule Statement

The safe and efficient functioning of the road network depends in part on the availability of convenient and safe parking, loading and manoeuvring facilities and on appropriate siting of access points.

In all zones except for the City Centre, land use activities are required to provide parking and loading on site. The Plan sets minimum parking and loading space requirements so that activities are readily accessed with minimum disruption to the functioning of the road network. The number of spaces required aims to provide for normal or reasonable requirements for staff, customers, or visitors. The Plan also provides standards relating to aspects of location and design of manoeuvring space so that the effects of vehicle movements on safety and efficiency of roads are minimised.

A cash payment in lieu of parking is allowed in the central city area, to be used by Council to accommodate the parking demand in the central area whether by providing aggregated parking or facilitating alternative means of transport.

The Plan's rules relating to the number and placement of access points aim to protect the road's function in the road hierarchy and to minimise disruption to the flow of traffic and adverse effects on the safety of other road users.

Expected Outcome

On-site parking and loading space providing easy access and mitigating any adverse effects of vehicle manoeuvring on the safe and efficient functioning of the road network and on neighbourhood amenity.

Means of Compliance

The following standards and assessment criteria are additional to those established within each zone. Where an activity cannot meet the standards, its activity status is established within the Failure to Meet Standards section of the relevant zone.

Regard must be had to all Objectives and Policies which may be relevant to any proposed activity subject to this Rule. This includes, but shall not be limited to, Policy Section 4.2 Transportation and Accessibility.

ADVISORY NOTE — Consultation with Transit New Zealand

For any development involving access onto and off a State highway consultation with Transit New Zealand is recommended before an application is submitted to Council. Under the Resource Management Act (Section 93) Transit New Zealand will be notified by Council if an application affects the State highway.

5.2.1 Standards

The following standards apply to all Permitted and Controlled Activities, and Restricted Discretionary Activities where they are listed as such in the activities list for the relevant zone.

a) Number of Parking Spaces

- i) Where any activity occurs on a site, parking shall be provided according to the standards given in Table 5.2-1a, Table 5.2-1b Table 5.2-1c and Table 5.2-d except that in those areas listed in Table 5.2-1e a cash payment will be accepted in lieu of part or all of the parking requirement.
- ii) Where the assessment of the number of parking spaces results in a fractional space, any fraction under one-half shall be disregarded and fractions of one-half or greater shall be considered as one space.
- iii) All parking areas shall include accessible parking spaces for persons with disabilities, as follows:
 - one space for carparks up to 10 spaces
 - two spaces for carparks with 11 to 99 spaces
 - one space for each additional 50 spaces commencing at 100 spaces.
- iv) Parking Lots (excluding car parking buildings) shall provide stands to accommodate bicycles on the site at the following rates:
 - 5 bicycles for car parks of 40 to 100 car parking spaces; and
 - one additional bicycle per 20 car parking spaces over 100 spaces.
- v) Parking Lots shall provide space specifically identified for motorcycle parking, as part of the overall parking space requirement, at the following rates:
 - space for 3 motorcycles (one car space equivalent) in car parks of 20 to 100 spaces; and
 - space for one additional motorcycle per 40 car spaces over 100 spaces.

b) Number of Loading Spaces

- i) Where any activity occurs on a site, loading space is to be provided according to Table 5.2-1a, Table 5.2-1c or Table 5.2-1d.
- ii) Access to the loading space shall be readily available from the individual occupancies in each tenancy or development on the site that the loading space is to serve.

c) Parking and Loading Space Dimensions and Layout

- i) Parking space dimensions and layout shall be in accordance with Figure 5.2-1.
- ii) Every car parking space shall accommodate the 90 percentile car tracking curve (Figure 5.2-2).
- iii) Dimensions for accessible car parks (for people with disabilities) should be as specified in NZS 4121.

- iv) The loading space dimension will be that given in Table 5.2-2 which accommodates the largest vehicle likely to service the site.
- v) Every general loading space shall accommodate the tracking curves for 99 percentile cars (Figure 5.2-3), 99 percentile truck (Figure 5.2-4) or articulated truck (Figure 5.2-5), whichever is appropriate given (iv) above.
- vi) No part of any parking or loading space shall be located on any outdoor living area or service area.
- vii) Not more than 50% of any required front set back area may be used to provide parking spaces, except in Suburban Centre, Commercial Service and City Centre Zones where all of the front set back may be used for parking.
- viii) No part of any parking or loading space or manoeuvring area shall be located between any building line for designated street widening purposes and the road boundary.
- ix) Side and rear set back areas may be used to provide parking spaces where practicable, except that in recreation zones the buffer or amenity function of side and rear set backs is to be met before any remaining area is used for parking purposes.
- x) Sufficient on-site manoeuvring area shall be constructed and provided to avoid the reversing of vehicles on to or off a site where:
 - any car park has access to any arterial road
 - the car parking area contains more than five parking spaces or is located more than 30m from the road boundary, on any road.
- xi) No loading space layout shall be permitted where vehicles project on to the road or any roadside footpath whilst loading or where the vehicle is required to reverse off or on to an arterial road to enter or leave the loading space.
- xii) Any vehicle occupying any parking or loading space must have ready access to a road at all times, without the necessity of moving any vehicle occupying any other parking or loading space, with the exception of residential units, where only one space per unit need be accessible at all times.

d) Access to Sites, Parking and Loading Spaces

Any activity shall provide access to the site as follows unless otherwise restricted by another zone rule.

- i) Sites with less than 20m site frontage shall have one crossing only.
- ii) Sites with road frontages greater than 20m shall be permitted two crossings per frontage greater than 20m, provided that the minimum distance between the two crossings shall be 7.5m.
- iii) Vehicle crossing and access widths shall be as specified in Table 5.2-3, subject to the relevant standards in [Rule 6.3](#).
- iv) Any vehicle access shall be provided with sufficient clearance from the edge of the formation to buildings, fences and other structures to enable the safe and unobstructed operation of the access.

- v) Where a vehicle access, which serves more than one residential unit or business occupancy or more than 5 carparking spaces, is less than 5.5m in width and has a length greater than 70m or unrestricted visibility is not available over its full length, then a passing bay located approximately midway shall be required.
- vi) For any corner site, only one vehicle access or crossing shall be permitted on each frontage, located as close as reasonably practicable to the furthest site boundary from the intersection.
- vii) Where a corner site has frontage to a major or minor arterial road as well as to a minor arterial, collector or local road, then any vehicle access or crossing shall be limited to the frontage located on the minor arterial, collector or local road.
- viii) The minimum sight distance from the crossing shall be as set out in Table 5.2-4 and Figure 5.2-6.
- ix) On roads where the posted speed limit is less than 80 km/hour, any vehicle access shall not be located closer to an intersection than the distance specified in Table 5.2-5. Distances shall be measured along the boundary parallel to the centre line of the frontage road from the kerb line or formed edge of the intersecting road (see Figure 5.2-7).
- x) On roads where the posted speed limit is 80 km/hour or greater, the minimum distance from an intersection of any vehicle access shall be the greater of the distance specified in Table 5.2-5 or:
 - 100m where the frontage roads is an arterial road
 - 30m where the frontage road is a collector or local road.Distances shall be measured along the boundary parallel to the centre line of the frontage road from the kerb line or formed edge of the intersecting road (see Figure 5.2-7).

e) Formation

- i) Except for a driveway to a single detached dwelling, any parking or loading space, access drives and aisles, and manoeuvring areas shall be formed and drained and maintained with permanent sealed or paved all weather, dust-free surface.
- ii) Where five or more parking and/or loading spaces are provided, such parking and loading spaces shall be clearly marked out and identified.
- iii) Where a parking or loading space, manoeuvring area, or any sealed or paved landscaped area in all zones (except the Residential Zone) adjoins a road, kerbing or a similar barrier not less than 0.125m high shall be provided on those parts of the frontage not used for vehicular access.

g) Dairies

- i) Dairies shall provide a stand to accommodate at least 2 bicycles.

Performance Assessment

5.2.2 Assessment Criteria

In determining any resource consent, Council shall have regard to the expected outcome of this rule and the relevant underlying zone, any related objectives and policies, and to the following.

a) Number of Parking Spaces

- i) The extent to which failure to provide the required number of on-site carparks will result in adverse effects of extra parked and manoeuvring vehicles on the traffic function of the road and on the function and safety of the surrounding road network.
- ii) The extent to which it can be demonstrated that the total parking demand generated by the proposed development is less than the number of spaces required.
- iii) The extent to which the hours of operation relative to other uses on the site or on adjoining sites provide opportunities for shared carparking.
- iv) The extent to which appropriate off-street public parking is available in the locality and is readily accessible by being:
 - within easy walking distance
 - does not require people to cross arterial roads to gain access to the activity.
- v) Parking may be provided on an alternative site, taking into account the following:
 - The extent to which the distance between the alternative parking site and the development is appropriate to the activity or service provided and whether it requires crossing of an arterial road
 - The extent to which the alternative site can be clearly associated or identified with the activity
 - The extent to which joint parking is acceptable, particularly where hours of operation are different
 - The desirability of avoiding vehicular access to the subject site on traffic or pedestrian safety groundsand provided that a legal agreement binds the alternative parking site to the development.
- vi) The extent to which parking is associated with pick up or drop off activities.
- vii) The extent to which the effects of not providing on-site parking are cumulative in conjunction with inadequate parking provision by other developments on the site.

b) Number of Loading Spaces

- i) The extent to which loading and unloading can occur without:
 - conflict with traffic or pedestrians on adjoining streets
 - giving rise to any traffic or pedestrian safety hazard
 - detracting from the amenities of the neighbourhood

- detrimental effects on the operation of any adjoining business.

c) Parking and Loading Space Dimensions and Layout

- i) The extent to which traffic function and safety of the surrounding road network is affected by vehicles entering or leaving the parking or loading space.
- ii) The extent to which safety of pedestrians and other users of the site is affected.
- iii) The extent to which the number of vehicles required to reverse on to or off a street is compatible with the traffic flow and safety of that street.

d) Access to Sites, Parking and Loading Spaces

- i) The extent to which location, number and configuration of vehicular accesses adversely affects the provision of on street parking or the amenity values of the locality, particularly of residential properties.
- ii) The extent to which location, number and configuration of vehicular access points give rise to traffic hazards through inadequate visibility and safe stopping distances, or conflict with the normal flow of traffic and movement of pedestrians and cyclists.
- iii) The extent to which the location or number of crossings will inhibit the utilisation of the site or obstruct access to services, having regard to the scale of the activity and its operational needs.
- iv) On a major arterial road, the extent to which the number of crossings can be minimised, taking into account the:
 - opportunities that exist for shared access
 - the volume and nature of the traffic generated
 - the siting of the access points with respect to traffic visibility and flow
 - the operational requirements of the activity.
- iv) The extent to which the siting of the access on corner sites disrupts traffic or conflicts with the function of the road as classified in the Road Hierarchy.
- v) In any defined shopping frontage, the extent to which:
 - vehicular access disrupts pedestrian movements, safety, and shelter
 - opportunities exist for shared access
 - conflict with pedestrian shopping activity is minimised
 - such vehicular access is essential for operation of adjoining businesses.

e) Formation

- i) The extent to which the surfacing material used will avoid adverse effects on the amenities of neighbouring properties and the locality through dust, unsightliness, surface flooding and tracking of material on to the street.
- ii) The extent to which adequate markings, signs, kerbs and lighting facilitate the efficient and safe operation of any parking or loading area.

Table 5.2-1a Number of Parking and Loading Spaces Required in all Zones Except City Centre and Recreation Environment Zones¹

Building or use	Car parking spaces required	Loading/service spaces required
Detached Dwellings	2 per household or dwelling	
Home occupations	2 per household plus 1 per non-resident employee	
Ancillary flats and apartment buildings	1 per unit or flat	
Residential Centres	1 park per resident plus 1 park per four bedrooms	
Managed Care Facilities and Rest Homes Emergency housing, rest homes and any other residential accommodation which provides board and lodging for managed care and/or support	1 park per 3 residents bedrooms plus 1 park per every full time equivalent staff member ²	
Camping Grounds	1 per unit, camp site or caravan site	
Visitor Accommodation	1 per unit plus one per 2 staff	1 space
Community Centre	1 per 30m ² gfa	1 space
Education and Training Facilities Child care facilities	1 per 30m ² gfa	1 drop-off car space per 10 children

¹ Activities in the road reserve are controlled by HCC Parking Bylaw.

² ENV-2010-AKL-000046

Schools - primary	2 per 3 full-time equivalent staff	1 drop-off car space per 10 children
Schools - intermediate and secondary	1 per full-time equivalent staff, plus 1 per 20 students aged 16 or over	4 drop-off car spaces and 1 bus space per 200 students
Facilities for Education and Training	1 per full-time equivalent staff, plus 1 per 20 students aged 16 or over which can be accommodated on site at any one time	4 drop-off car spaces and 1 bus space per 200 students
Tertiary Education facilities	1 per 50m ² gfa	1 space
Health Care Services	3 per consultant and 1 per staff	1 space
Hospitals	1 per 2 beds	1 space per 50 beds
Playing Fields, Outdoor Courts	6 per field or court	
Buildings serving recreation reserves and indoor recreation buildings	1 per 20m ² gfa	1 space
Places of Assembly		
All Places of assembly (except Libraries and Museums)	1 per 25m ² gfa	1 space

Marae	1 per 25m ² gfa	1 space
Offices (excluding offices in the Commercial Service Zone surrounding the City Centre Zone — see Table 5.2-1d))	1 per 40m ² gfa	1 space
Retail Activities (excluding retail activities in the Commercial Service Zone surrounding the City Centre Zone — see Table 5.2-1d))		
Retail Activities (gfa less than 5,000m ² - in individual ownership/tenancy or integrated retail development)	1 per 20m ² gfa	1 space
Retail Activities (gfa greater than 5,000m ² and less than 10,000m ² gfa- in individual ownership/tenancy or integrated retail development)	1 per 30m ² gfa	1 space
Retail Activities (gfa greater than 10,000m ² — in individual ownership/tenancy or integrated retail development)	1 per 40m ² gfa	1 space
Outdoor Retailing	1 per 100m ² of uncovered display area	1 space
Indoor Display Areas for Vehicles, Boats and Agricultural and Industrial Machinery	1 per 50m ² gfa	1 space

Supermarkets	1 per 20m ² gfa	1 space
Libraries and Museums	1 per 30m ² gfa	1 space
Produce Stalls	1 per 16m ² retail space	1 space
Restaurants and Licensed Premises	1 per 10m ² gfa	1 space
Drive-Through Services	1 per 30m ² gfa (excluding canopy area over pumps) plus 5 queuing spaces per dispensing facility	1 space
Industrial Activities (including Warehouses)	1 per 60m ² gfa for the first 1,000m ² of an individual ownership or tenancy, 1 per 100m ² thereafter	1 space per development or per 3,000m ² gfa, whichever is the greater
Transport Depots	1 per 100m ² gfa of building or site area used for storage, whichever is the greater	1 space
Fire Stations	2 car parks per 3 staff members	

* gfa = gross floor area

Table 5.2-1b Number of Parking Spaces Required in Recreation Environment Zone:

Activity	Car parking spaces required
All activities	Nil

Table 5.2-1c Number of Parking and Loading Spaces Required in City Centre Zone

Activity	Car parking spaces required	Loading Spaces Required
Residential	1 per residential unit	Nil
All activities other than residential	Payment or spaces provided at 1 per 160m ² gfa	1 per site

Table 5.2-1d) Number of Parking and Loading Spaces Required for Offices and Retail Activities in the Commercial Service Zone Surrounding the City Centre Zone

Activity	Car Parking Spaces Required	Loading Spaces Required
Offices	1 space per 80m ²	1
Retail Activities	1 space per 80m ²	1 per activity (in individual ownership/tenancy or integrated retail development)

Table 5.2-1e Cash in Lieu of Parking

Zone	Area	Value Required
City Centre	The area bounded by London, Anglesea and Hood Streets, Marlborough Place and The Waikato River	\$13,430 per space or the value of 24m ² per space of the site, whichever is the lesser ^a

^aThe figure of \$13,430 is in 1997 terms and will be adjusted at the same rate as the Producers Price Index for Construction

Table 5.2-2 Loading Space Dimensions

Activity	Minimum width (m)	Minimum length (m)	Minimum height (m)	Manoeuvring area
Activities serviced by Courier vans only	3.0	6.0	3.2	Figure 5.2.3
Activities serviced by vans (other than Courier vans) and non-articulated trucks	4.0	8.0	4.5	Figure 5.2.4
Activities serviced by articulated vehicles	4.0	20.0	4.5	Figure 5.2.5

Table 5.2-3 Widths of Crossings and Vehicle Access³

Crossings		Width of Formation (m)	
		Minimum	Maximum
Residential Zone		3	5.5
Commercial Service, Suburban Centre, City Centre and Industrial Zone		5	7.5

Entrances and Vehicle Accesses	Use of Access	Minimum Width of Formation (m)
Residential - units	1-4 units	2.8
	5-10 units	5.5
	More than 10 units	6
Residential Centres, Visitor Accommodation	1-12 occupants	2.8
	More than 12 occupants	5.5
Commercial Service, Suburban Centre, City Centre and Industrial Activities	up to 5 occupancies	6
	more than 5 occupancies	8
Car Parking Facilities	Up to 15 spaces	3
	More than 15 spaces	6

Table 5.2-4 Minimum Sight Distances (m) - see Figure 5.2.6

Operating speed (km/h) ^a	Frontage road classification		
	Local	Collector	Arterials
40	30	35	70
50	40	45	90
60	55	65	115
70	85	85	140
80	105	105	175
90	130	130	210
100	160	160	250
110	190	190	290
120	230	230	330

^aOperating Speed = 85th percentile speed on frontage road, taken as the speed limit plus 15%.

³ Hamilton City Council will apply the Local Government Act 1974 to require action to prevent damage to the road berm from crossings being of inadequate width or construction.

**Table 5.2-5 Minimum Distance (m) of Vehicle Access from an Intersection^a
(Also see Rule 5.2.1 d) x))**

Frontage road	Intersecting road type			
	Major arterial	Minor arterial	Collector	Local
Major arterial	70	55	40	40
Minor arterial	55	55	40	35
Collector	40	40	40	15
Local	40	25	15	10

^aWhere the boundaries of the site do not allow the provision of a vehicle access which conforms with the above distances, a vehicle crossing may be constructed in the position which most closely complies with the provisions in Table 5.2-5.

Figure 5.2-1 Car Manoeuvring and Parking Space Dimensions

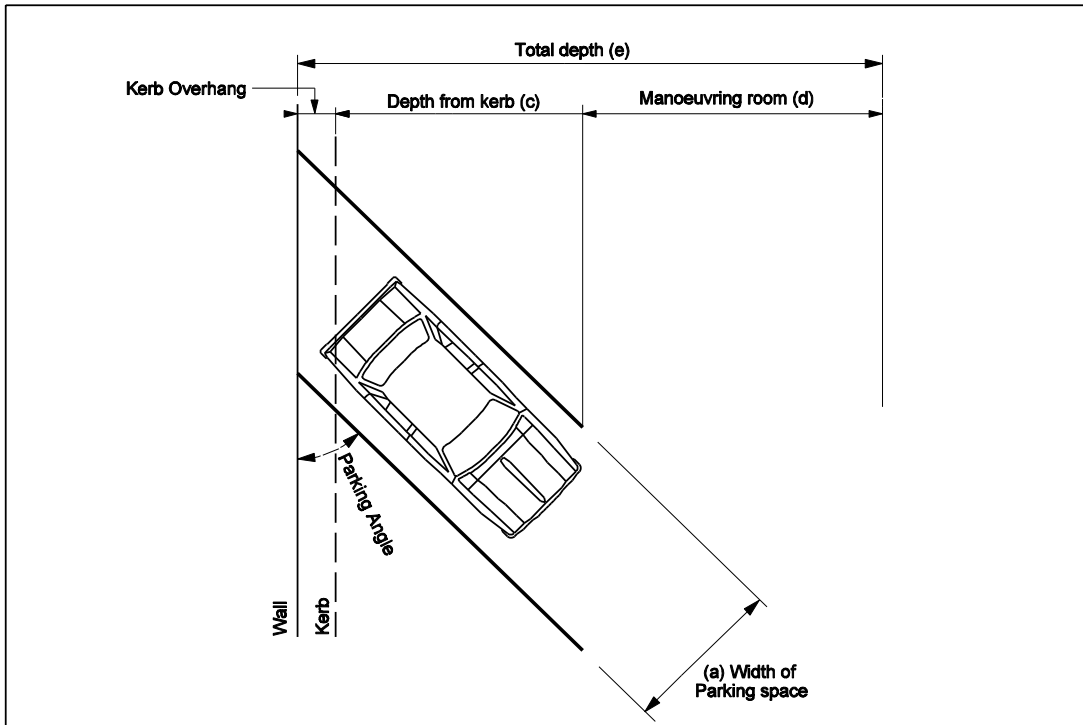

Type of Parking		Stall Width (a)	Stall Depth		Manoeuvre Width (d)	Total Depth (e)		
Parking Angle	Type		from wall (b)	from kerb (c)		one row	two rows	
ALL MEASUREMENTS ARE IN METRES								
90	Nose in	2.4	5.1	4.1	7.9	13.0	18.1	
		2.5			7.6			12.7
		2.6			7.2			12.3
		2.7			6.8			11.9
75	Nose in	2.4	5.4	4.4	6.4	11.3	17.2	
		2.5			5.8			11.2
		2.6			5.2			10.6
		2.7			4.6			10.0
60	Nose in	2.4	5.4	4.5	4.5	9.9	15.3	
		2.5			4.2			9.6
		2.6			3.9			9.3
		2.7			3.6			9.0
45	Nose in	2.4	5.0	4.2	3.6	8.6	13.6	
		2.5			3.5			8.5
		2.6			3.4			8.4
		2.7			3.3			8.3
30	Nose in	2.4	4.3	3.7	3.0	7.3	11.6	
		2.5						
		2.6						
		2.7						
0	Parallel	2.5	Stall length 6.0 m		3.7	6.2	8.7	

1. Parallel parking spaces (Parking Angle = 0) shall be 6.0m long, except where one end of the space is not obstructed, in which case the length of a space may be reduced to 5.0m.
2. Minimum aisle and accessway widths shall be 3.0m for one way flow, and 5.5m for two way flow. Recommended aisle and accessway widths are 3.5m for one way flow, and 6.0m for two way flow.
3. Maximum kerb height = 150mm

Figure 5.2-2 90 Percentile Car Tracking Curve Minimum Radius

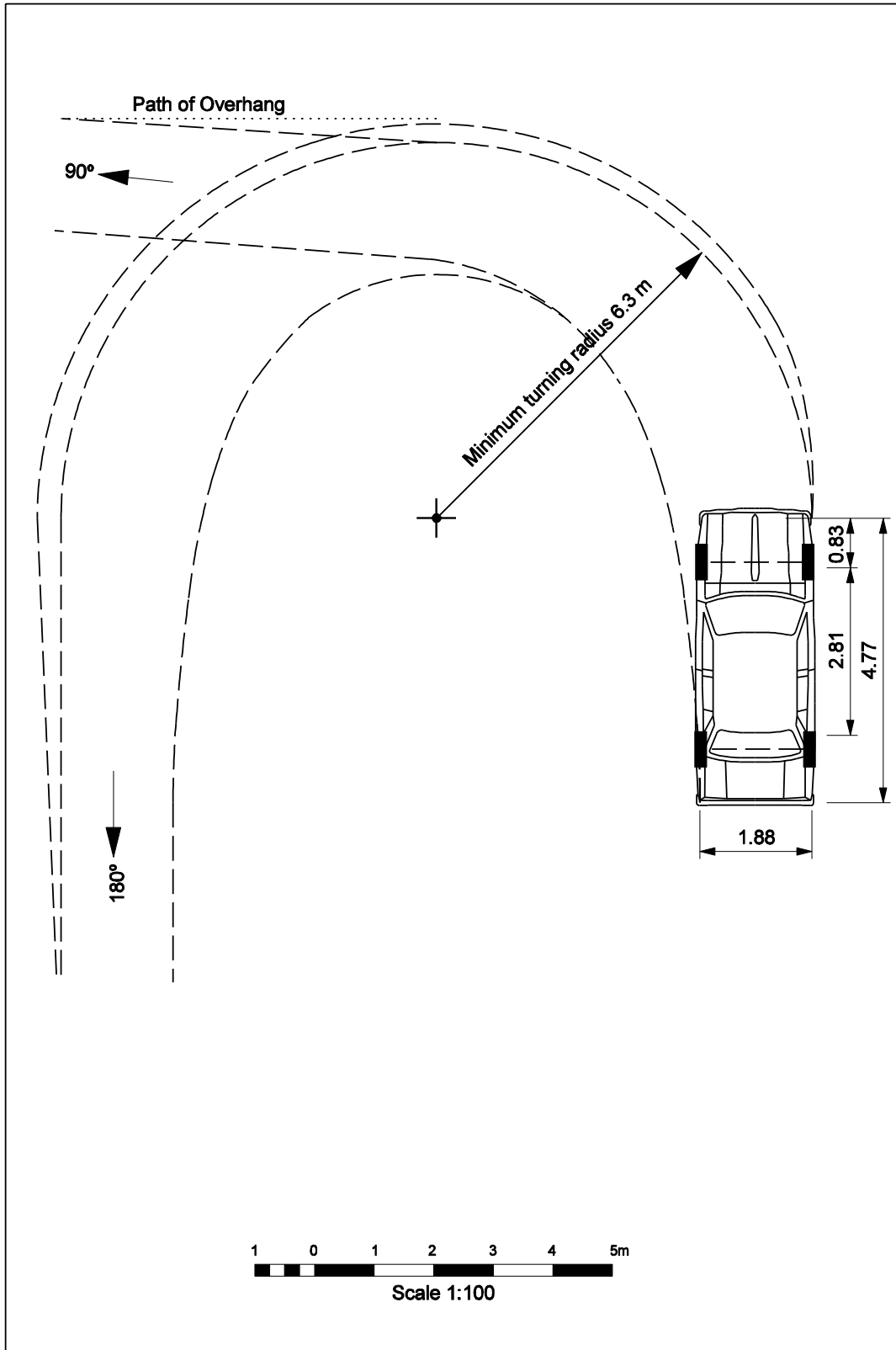

Figure 5.2-3 99 Percentile Car Tracking Curve Minimum Radius

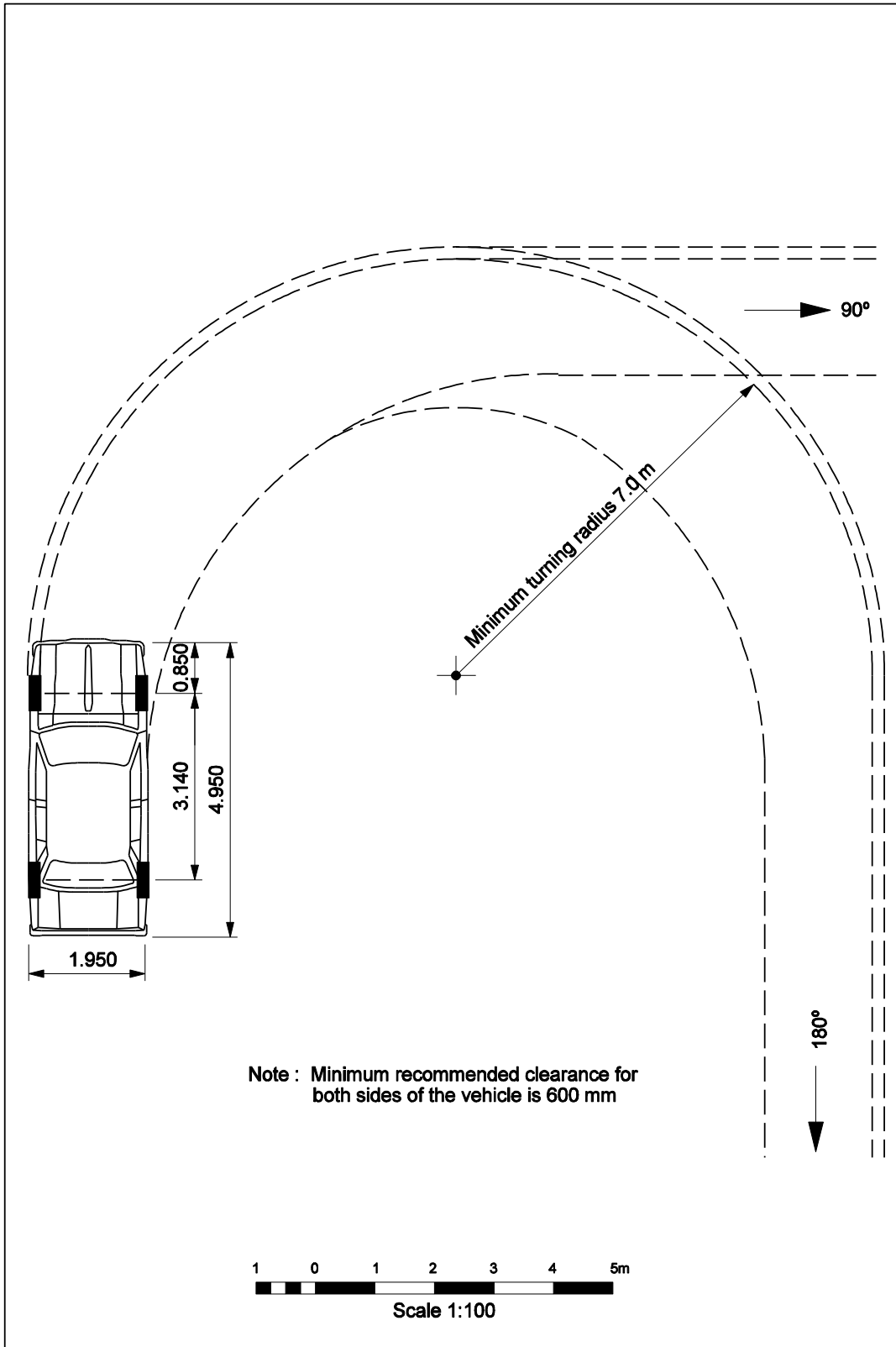

Figure 5.2-4 99 Percentile Truck Tracking Curve Minimum Radius

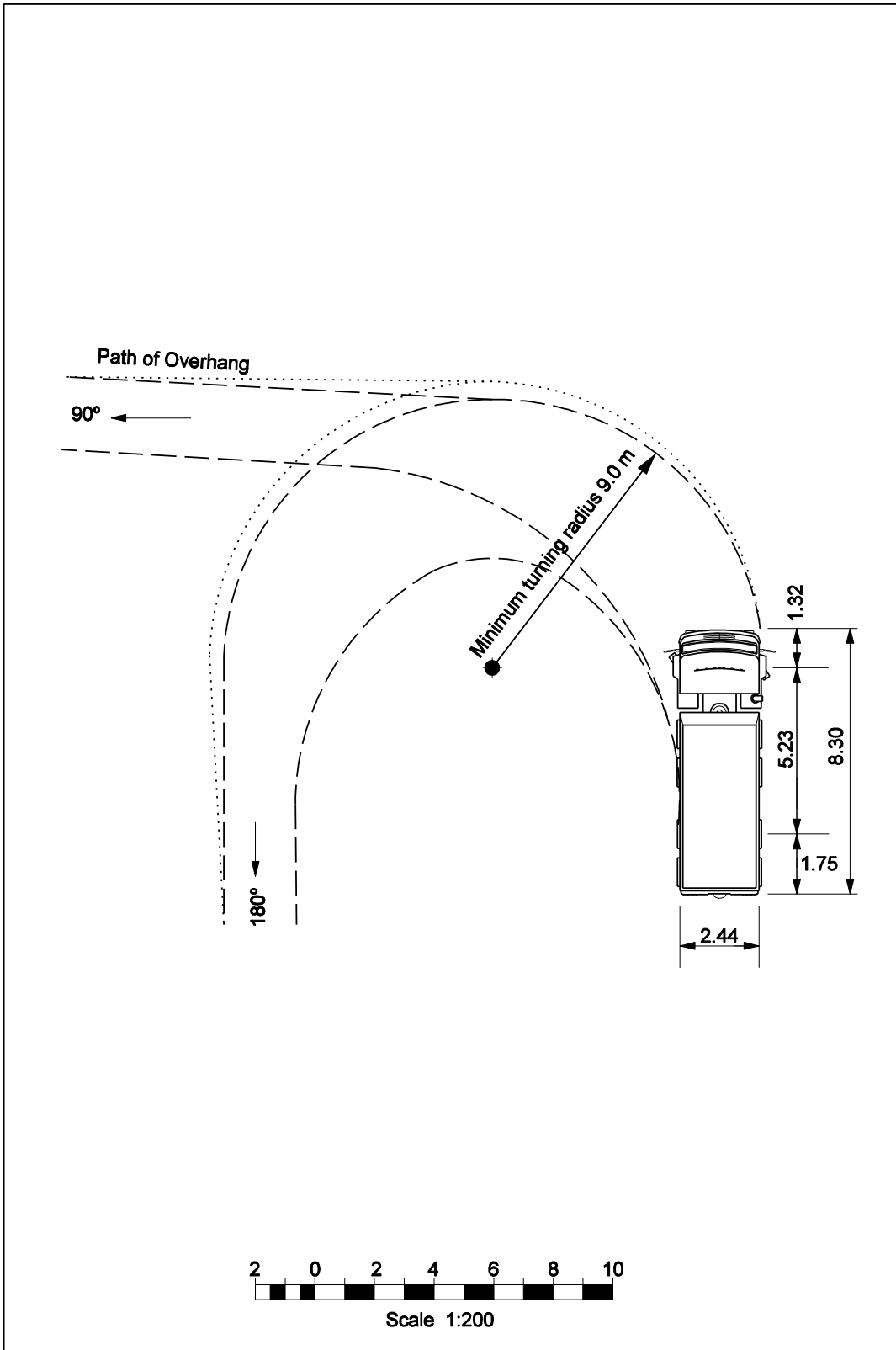

Figure 5.2-5 Maximum Legal 'B' Train Tracking Curve Minimum Radius

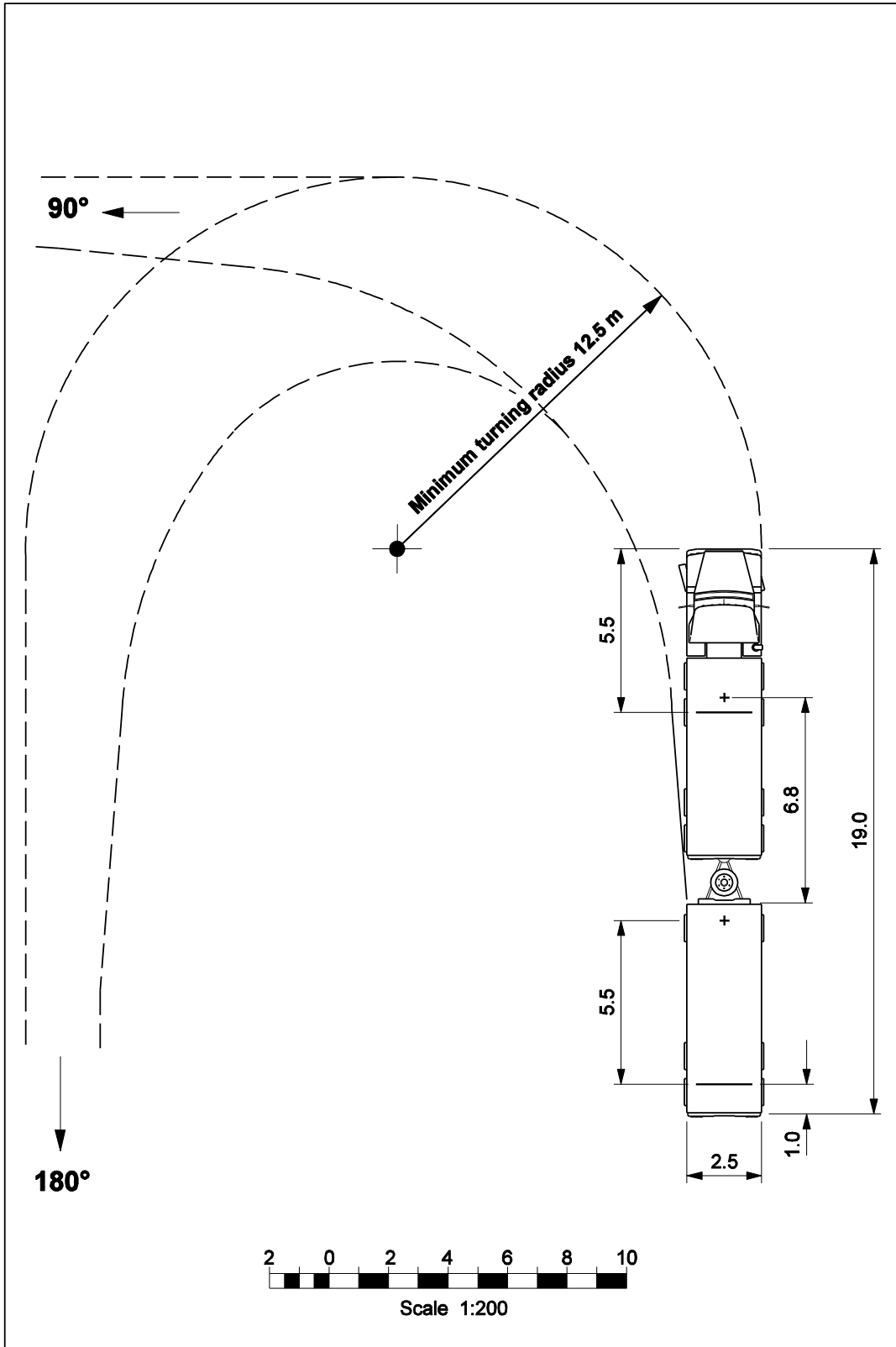
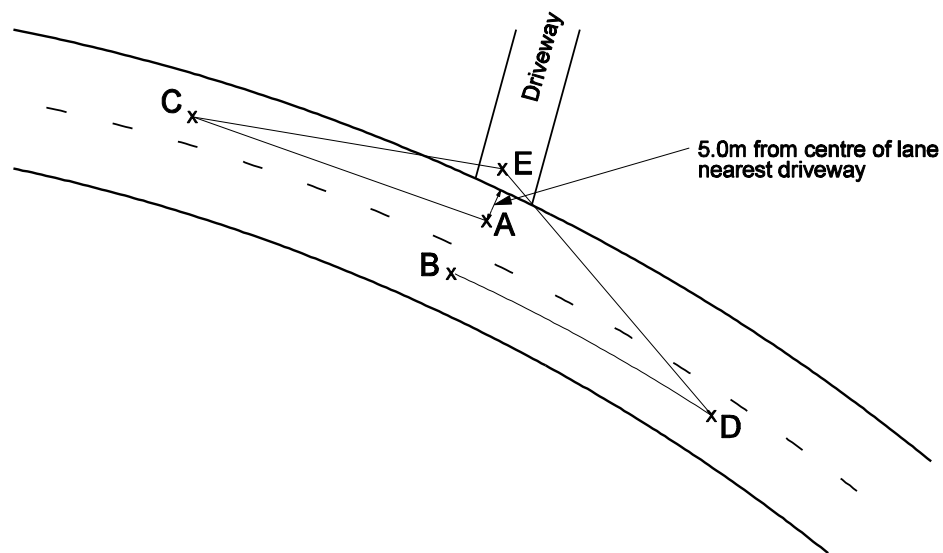

Figure 5.2.6 Sight Distance Measurement

There should be lines of clear sight from driver's eye height to driver's eye height (1.15 metres above ground level) along the lines detailed below

- Lines AC and BD- All driveways, all roads
- Lines EC and ED All driveways on collector and arterial roads

Points A, B, C and D are established by measuring the sight distance from Table 5.2 - 4 along the centre of the appropriate lane from points A and B. For practical purposes A and B can be taken as opposite the centre of the driveway



(Source: Land Transport, Road and Traffic Standards: Guidelines for Visibility at Driveways)

Figure 5.2-7 Measuring Distances of Vehicle Accesses from an Intersection

